

Silicon NPN Power Transistors

2N6386 2N6387 2N6388

DESCRIPTION

- With TO-220C package
- Complement to type 2N6666/6667/6668
- DARLINGTON
- High DC current gain
- Low collector saturation voltage

APPLICATIONS

- Designed for general-purpose amplifier and low speed switching applications

PINNING

PIN	DESCRIPTION
1	Base
2	Collector;connected to mounting base
3	Emitter

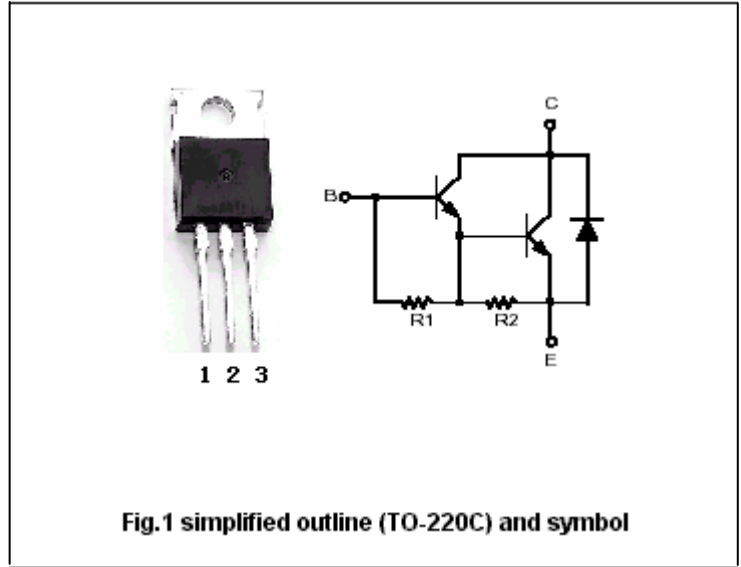

Absolute maximum ratings(Tc=25)

SYMBOL	PARAMETER	CONDITIONS	VALUE	UNIT
V _{CBO}	Collector-base voltage	2N6386	40	V
		2N6387	60	
		2N6388	80	
V _{CEO}	Collector-emitter voltage	2N6386	40	V
		2N6387	60	
		2N6388	80	
V _{EBO}	Emitter-base voltage	Open collector	5	V
I _C	Collector current-DC	2N6386	8	A
		2N6387/6388	10	
I _{CM}	Collector current-Pulse		15	A
I _B	Base current-DC		0.25	A
P _C	Collector power dissipation	T _C =25	65	W
T _j	Junction temperature		150	
T _{stg}	Storage temperature		-65~150	

Silicon NPN Power Transistors

2N6386 2N6387 2N6388

CHARACTERISTICS

T_j=25 unless otherwise specified

SYMBOL	PARAMETER	CONDITIONS	MIN	TYP.	MAX	UNIT
V _{CEO(SUS)}	Collector-emitter sustaining voltage	2N6386	I _C =0.2A, I _B =0	40		V
		2N6387		60		
		2N6388		80		
V _{CEsat-1}	Collector-emitter saturation voltage	2N6386	I _C =3A, I _B =6mA		2.0	V
		2N6387/6388	I _C =5A, I _B =10mA			
V _{CEsat-2}	Collector-emitter saturation voltage	2N6386	I _C =8A, I _B =80mA		3.0	V
		2N6387/6388	I _C =10A, I _B =100mA			
V _{BE-1}	Base-emitter on voltage	2N6386	I _C =3A; V _{CE} =3V		2.8	V
		2N6387/6388	I _C =5A; V _{CE} =3V			
V _{BE-2}	Base-emitter on voltage	2N6386	I _C =8A; V _{CE} =3V		4.5	V
		2N6387/6388	I _C =10A; V _{CE} =3V			
I _{CBO}	Collector cut-off current	2N6386	V _{CB} =40V, V _{BE} =-1.5V T _C =125		0.3 3.0	mA
		2N6387	V _{CB} =60V, V _{BE} =-1.5V T _C =125		0.3 3.0	
		2N6388	V _{CB} =80V, V _{BE} =-1.5V T _C =125		0.3 3.0	
I _{CEO}	Collector cut-off current	2N6386	V _{CE} =40V, I _B =0		1.0	mA
		2N6387	V _{CE} =60V, I _B =0			
		2N6388	V _{CE} =80V, I _B =0			
I _{EBO}	Emitter cut-off current	V _{EB} =5V; I _C =0			5.0	mA
h _{FE-1}	DC current gain	2N6386	I _C =3A; V _{CE} =3V	1000	20000	
		2N6387/6388	I _C =5A; V _{CE} =3V			
h _{FE-2}	DC current gain	2N6386	I _C =8A; V _{CE} =3V	100		
		2N6387/6388	I _C =10A; V _{CE} =3V			
C _{ob}	Output capacitance	I _E =0; V _{CB} =10V, f=0.1MHz			200	pF

THERMAL CHARACTERISTICS

SYMBOL	PARAMETER	VALUE	UNIT
R _{th j-c}	Thermal resistance junction to case	1.92	/W

Silicon NPN Power Transistors

2N6386 2N6387 2N6388

PACKAGE OUTLINE

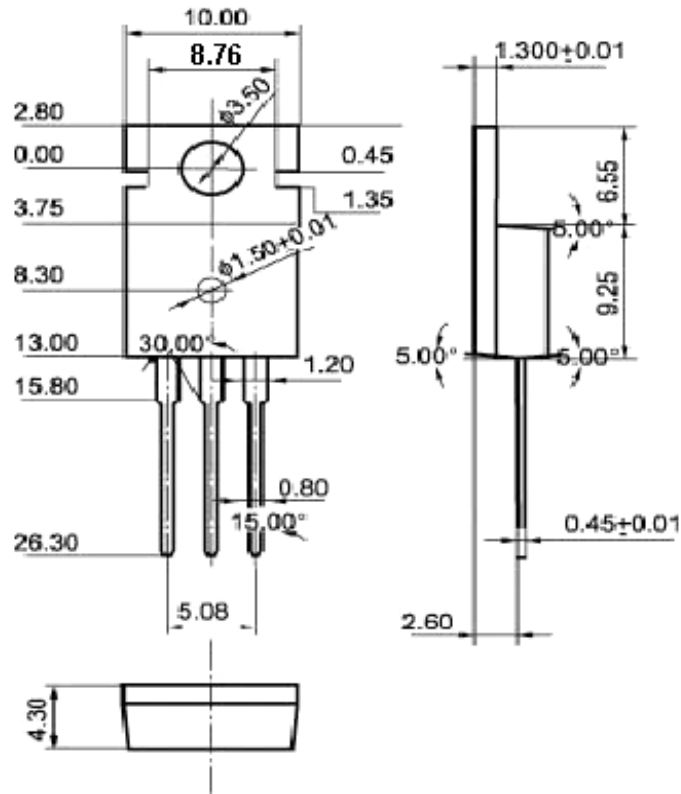

Fig.2 Outline dimensions