

**Silicon NPN Power Transistors**

**2SC3874**

**DESCRIPTION**

- With TO-3PL package
- High speed switching
- High  $V_{CBO}$
- Wide area of safe operation

**APPLICATIONS**

- For high-speed switching applications

**PINNING**

PIN	DESCRIPTION
1	Base
2	Collector;connected to mounting base
3	Emitter

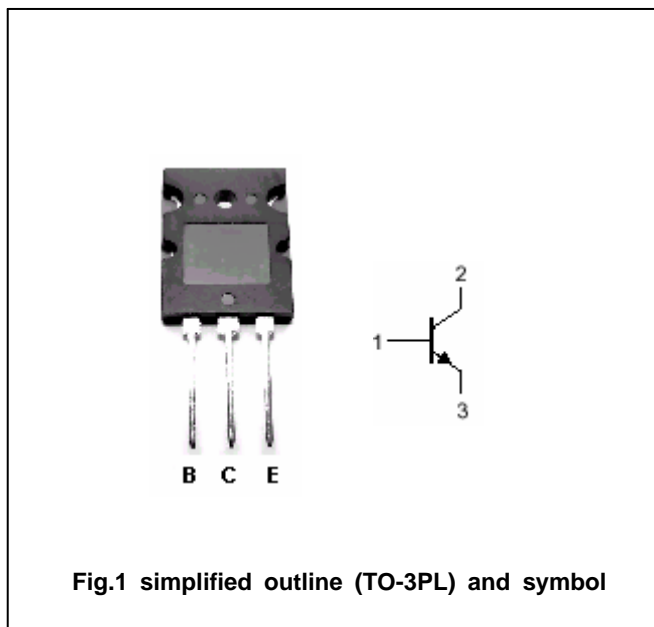

**Absolute maximum ratings ( $T_a=25$  )**

SYMBOL	PARAMETER	CONDITIONS	VALUE	UNIT
$V_{CBO}$	Collector-base voltage	Open emitter	500	V
$V_{CEO}$	Collector-emitter voltage	Open base	400	V
$V_{EBO}$	Emitter-base voltage	Open collector	7	V
$I_C$	Collector current		15	A
$I_{CM}$	Collector current-peak		25	A
$I_B$	Base current		5	A
$P_C$	Collector power dissipation	$T_a=25$	3.5	W
		$T_C=25$	150	
$T_j$	Junction temperature		150	
$T_{stg}$	Storage temperature		-55~150	

## Silicon NPN Power Transistors

## 2SC3874

## CHARACTERISTICS

T<sub>j</sub>=25 unless otherwise specified

SYMBOL	PARAMETER	CONDITIONS	MIN	TYP.	MAX	UNIT
V <sub>(BR)CEO</sub>	Collector-emitter breakdown voltage	I <sub>C</sub> =10mA ; I <sub>B</sub> =0	400			V
V <sub>CEsat</sub>	Collector-emitter saturation voltage	I <sub>C</sub> =10A ; I <sub>B</sub> =2A			1.0	V
V <sub>BEsat</sub>	Base-emitter saturation voltage	I <sub>C</sub> =10A ; I <sub>B</sub> =2A			1.5	V
I <sub>CBO</sub>	Collector cut-off current	V <sub>CB</sub> =500V; I <sub>E</sub> =0			100	μ A
I <sub>EBO</sub>	Emitter cut-off current	V <sub>EB</sub> =5V; I <sub>C</sub> =0			100	μ A
h <sub>FE-1</sub>	DC current gain	I <sub>C</sub> =0.1A ; V <sub>CE</sub> =5V	15			
h <sub>FE-2</sub>	DC current gain	I <sub>C</sub> =10A ; V <sub>CE</sub> =5V	8			
f <sub>T</sub>	Transition frequency	I <sub>C</sub> =1A ; V <sub>CE</sub> =10V; f=1MHz		20		MHz

## Switching times

t <sub>on</sub>	Turn-on time	I <sub>C</sub> =10A; V <sub>CC</sub> =150V I <sub>B1</sub> =2A; I <sub>B2</sub> =-4A			0.7	μ s
t <sub>stg</sub>	Storage time				2.0	μ s
t <sub>f</sub>	Fall time				0.3	μ s

Silicon NPN Power Transistors

2SC3874

PACKAGE OUTLINE

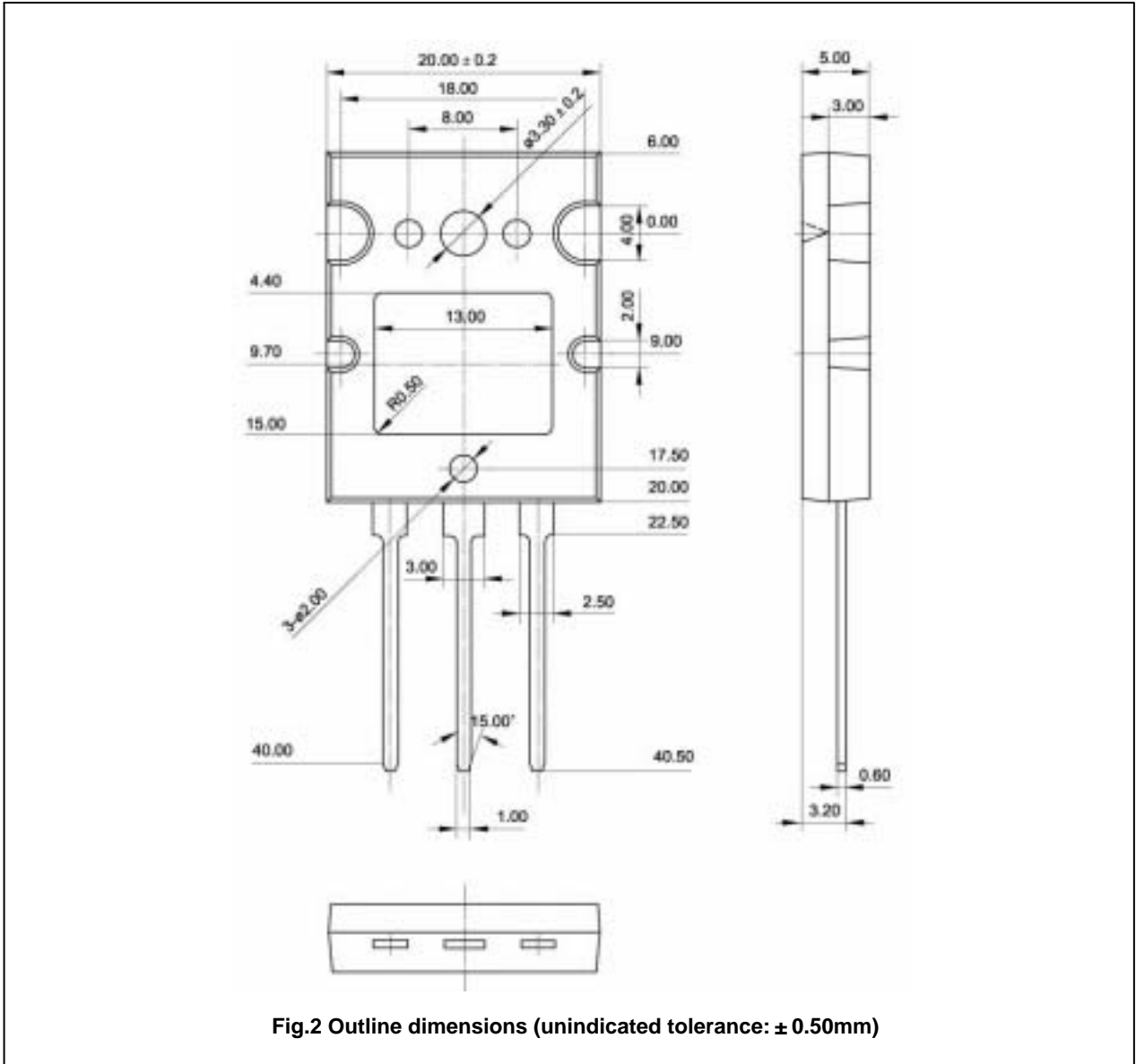

Fig.2 Outline dimensions (unindicated tolerance:  $\pm 0.50$ mm)

Silicon NPN Power Transistors

2SC3874

