

Silicon NPN Power Transistors

2SC4053

DESCRIPTION

- With TO-220C package
- High voltage,High speed switching
- High reliability

PINNING

PIN	DESCRIPTION
1	Base
2	Collector;connected to mounting base
3	Emitter

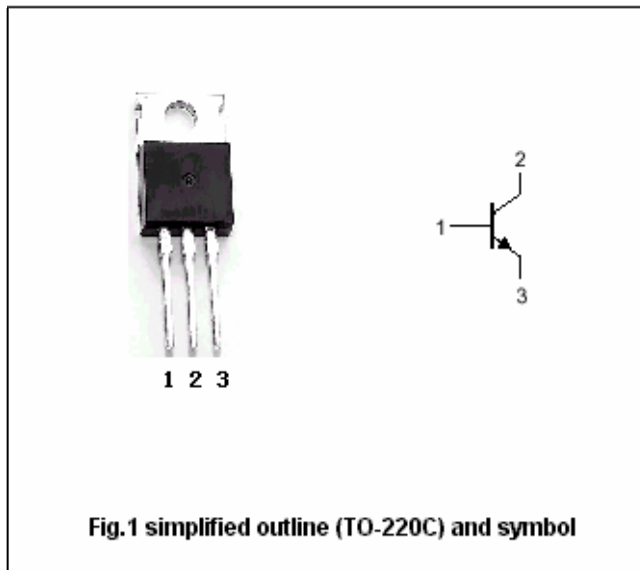

Absolute maximum ratings(Ta=25)

SYMBOL	PARAMETER	CONDITIONS	VALUE	UNIT
V _{CBO}	Collector-base voltage	Open emitter	600	V
V _{CEO}	Collector-emitter voltage	Open base	450	V
V _{EBO}	Emitter-base voltage	Open collector	7	V
I _C	Collector current		5	A
I _{CM}	Collector current-peak		10	A
I _B	Base current		2	A
I _{BM}	Base current-peak		4	A
P _C	Collector dissipation	T _C =25	50	W
T _j	Junction temperature		150	
T _{stg}	Storage temperature		-55~150	

THERMAL CHARACTERISTICS

SYMBOL	PARAMETER	MAX	UNIT
R _{th j-c}	Thermal resistance junction to case	2.5	/W

Silicon NPN Power Transistors

2SC4053

CHARACTERISTICS

T_j=25 unless otherwise specified

SYMBOL	PARAMETER	CONDITIONS	MIN	TYP.	MAX	UNIT
V _{CEO(SUS)}	Collector-emitter sustaining voltage	I _C =0.1A ; I _B =0	450			V
V _{CEsat}	Collector-emitter saturation voltage	I _C =2.5A; I _B =0.5A			1.0	V
V _{BEsat}	Base-emitter saturation voltage	I _C =2.5A; I _B =0.5A			1.5	V
I _{CBO}	Collector cut-off current	At rated voltage			0.1	mA
I _{CEO}	Collector cut-off current	At rated voltage			0.1	mA
I _{EBO}	Emitter cut-off current	At rated voltage			0.1	mA
h _{FE-1}	DC current gain	I _C =2.5A ; V _{CE} =5V	10			
h _{FE-2}	DC current gain	I _C =1mA ; V _{CE} =5V	5			
f _T	Transition frequency	I _C =0.5A ; V _{CE} =10V		20		MHz

Switching times

t _{on}	Turn-on time	I _C =2.5A; I _{B1} =0.5A; I _{B2} =1A; R _L =60 V _{BB2} =4V			0.5	μs
t _{stg}	Storage time				2.0	μs
t _f	Fall time				0.2	μs

Silicon NPN Power Transistors

2SC4053

PACKAGE OUTLINE

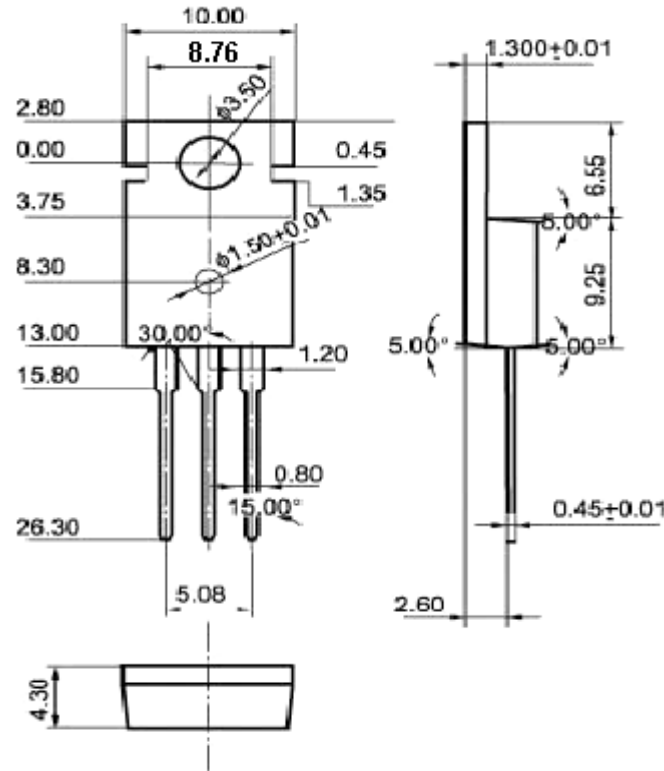

Fig.2 Outline dimensions (unindicated tolerance: ± 0.10 mm)