

**Silicon NPN Power Transistors**

**2SD1197**

**DESCRIPTION**

- With TO-3PN package
- High DC current gain.
- Large current capacity and wide ASO.
- Low saturation voltage.

**APPLICATIONS**

- Motor drivers, printer hammer drivers, relay drivers, voltage regulator control.

**PINNING**

PIN	DESCRIPTION
1	Base
2	Collector; connected to mounting base
3	Emitter

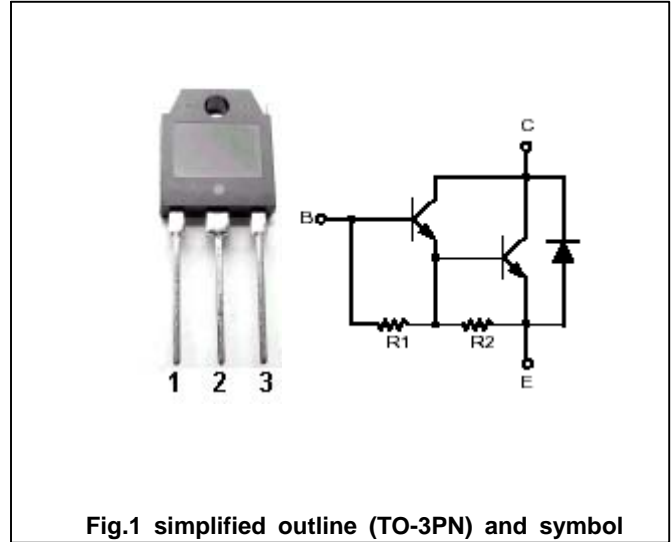

Fig.1 simplified outline (TO-3PN) and symbol

**Absolute maximum ratings(Tc=25 )**

SYMBOL	PARAMETER	CONDITIONS	VALUE	UNIT
V <sub>CBO</sub>	Collector-base voltage	Open emitter	110	V
V <sub>CEO</sub>	Collector-emitter voltage	Open base	100	V
V <sub>EBO</sub>	Emitter-base voltage	Open collector	6	V
I <sub>C</sub>	Collector current (DC)		10	A
I <sub>CP</sub>	Collector current (Pulse)		15	A
P <sub>C</sub>	Collector power dissipation	T <sub>c</sub> =25	70	W
T <sub>j</sub>	Junction temperature		150	
T <sub>stg</sub>	Storage temperature		-55~150	

## Silicon NPN Power Transistors

## 2SD1197

## CHARACTERISTICS

T<sub>j</sub>=25 unless otherwise specified

SYMBOL	PARAMETER	CONDITIONS	MIN	TYP.	MAX	UNIT
V <sub>CEO</sub>	Collector-emitter breakdown voltage	I <sub>C</sub> =50mA ; R <sub>BE</sub> =∞	100			V
V <sub>CBO</sub>	Collector-base breakdown voltage	I <sub>C</sub> =5mA ; I <sub>E</sub> =0	110			V
V <sub>CEsat</sub>	Collector-emitter saturation voltage	I <sub>C</sub> =5A; I <sub>B</sub> =10mA		1.0	1.5	V
V <sub>BEsat</sub>	Collector-base saturation voltage	I <sub>C</sub> =5A; I <sub>B</sub> =10mA			2.0	V
I <sub>CBO</sub>	Collector cut-off current	V <sub>CB</sub> =80V; I <sub>E</sub> =0			0.1	mA
I <sub>EBO</sub>	Emitter cut-off current	V <sub>EB</sub> =5V; I <sub>C</sub> =0			3.0	mA
h <sub>FE</sub>	DC current gain	I <sub>C</sub> =5A ; V <sub>CE</sub> =3V	1500	4000		
f <sub>T</sub>	Transition frequency	I <sub>C</sub> =5A ; V <sub>CE</sub> =5V		20		MHz

Silicon NPN Power Transistors

2SD1197

PACKAGE OUTLINE

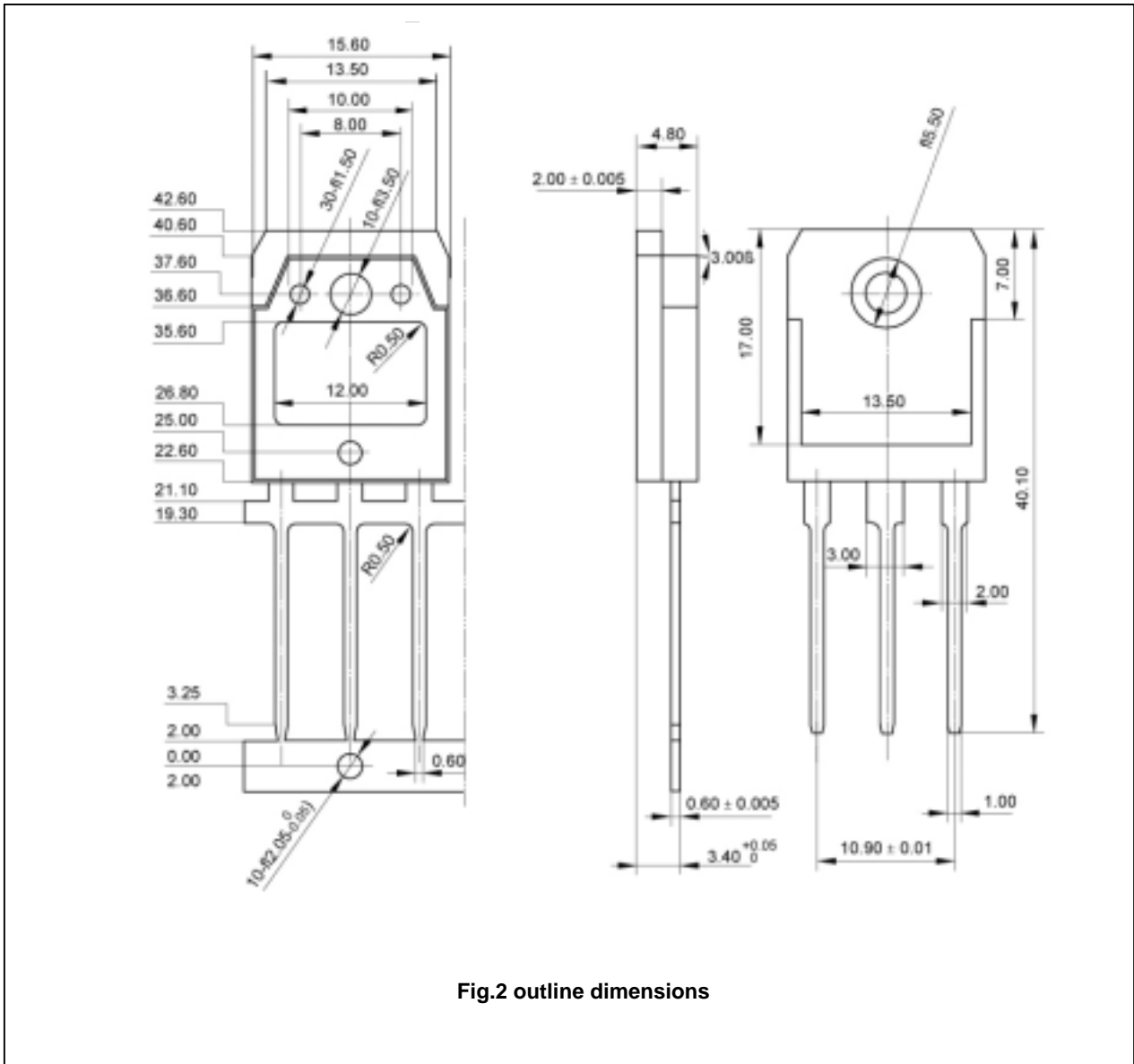

Fig.2 outline dimensions