

Silicon NPN Power Transistors

BD743/A/B/C

DESCRIPTION

- With TO-220C package
- Complement to type BD744/A/B/C
- High current capability
- High power dissipation

APPLICATIONS

- For use in power linear and switching applications

PINNING

PIN	DESCRIPTION
1	Base
2	Collector;connected to mounting base
3	Emitter

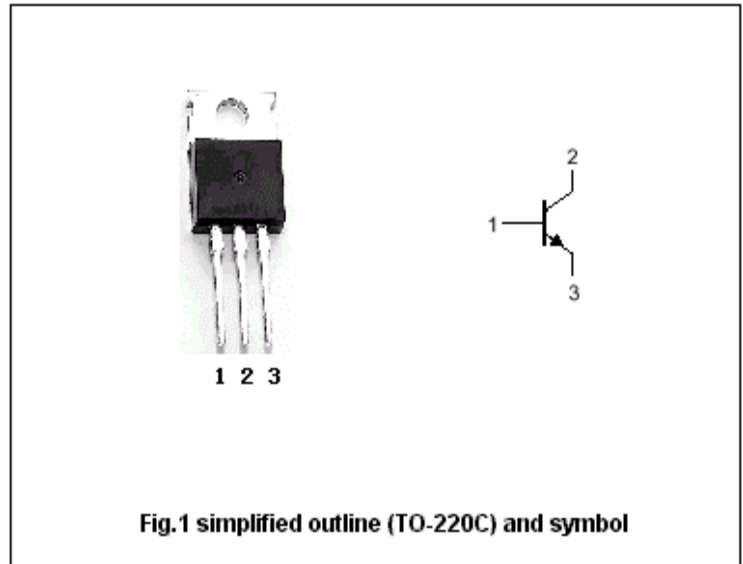

Fig.1 simplified outline (TO-220C) and symbol

Absolute maximum ratings (Ta=25)

SYMBOL	PARAMETER	CONDITIONS	VALUE	UNIT
V _{CB0}	Collector-base voltage	BD743	50	V
		BD743A	70	
		BD743B	90	
		BD743C	110	
V _{CEO}	Collector-emitter voltage	BD743	45	V
		BD743A	60	
		BD743B	80	
		BD743C	100	
V _{EBO}	Emitter-base voltage	Open collector	5	V
I _C	Collector current		15	A
I _{CM}	Collector current-peak		20	A
I _B	Base current		5	A
P _C	Collector power dissipation	T _C =25	90	W
		T _a =25	2	
T _j	Junction temperature		150	
T _{stg}	Storage temperature		-65~150	

Silicon NPN Power Transistors

BD743/A/B/C

CHARACTERISTICS

T_j=25 unless otherwise specified

SYMBOL	PARAMETER	CONDITIONS	MIN	TYP.	MAX	UNIT	
V _{(BR)CEO}	Collector-emitter breakdown voltage	BD743	I _C =30mA; I _B =0			V	
		BD743A					
		BD743B					
		BD743C					
V _{CEsat-1}	Collector-emitter saturation voltage	I _C =5 A; I _B =0.5 A			1.0	V	
V _{CEsat-2}	Collector-emitter saturation voltage	I _C =15 A; I _B =5 A			3.0	V	
V _{BE-1}	Base-emitter on voltage	I _C =5A ; V _{CE} =4V			1.0	V	
V _{BE-2}	Base-emitter on voltage	I _C =15A ; V _{CE} =4V			3.0	V	
I _{CEO}	Collector cut-off current	BD743/A	V _{CE} =30V; I _B =0			0.1	mA
		BD743B/C					
I _{CBO}	Collector cut-off current	BD743	V _{CE} =50V; V _{BE} =0 T _C =125			0.1	mA
		BD743A				5.0	
		BD743B				0.1	
		BD743C				5.0	
I _{EBO}	Emitter cut-off current	V _{EB} =5V; I _C =0			0.5	mA	
h _{FE-1}	DC current gain	I _C =1A ; V _{CE} =4V	40				
h _{FE-2}	DC current gain	I _C =5A ; V _{CE} =4V	20		150		
h _{FE-3}	DC current gain	I _C =15A ; V _{CE} =4V	5				

Switching times resistive load

t _d	Delay time	I _C =5 A; I _{B1} =-I _{B2} =0.5 A V _{BE(off)} =-4.2V; R _L =6 t _p =20 μs		0.02		μs
t _r	Rise time			0.35		μs
t _s	Storage time			0.5		μs
t _f	Fall time			0.4		μs

THERMAL CHARACTERISTICS

SYMBOL	PARAMETER	MAX	UNIT
R _{th j-c}	Thermal resistance junction to case	1.40	/W

Silicon NPN Power Transistors

BD743/A/B/C

PACKAGE OUTLINE

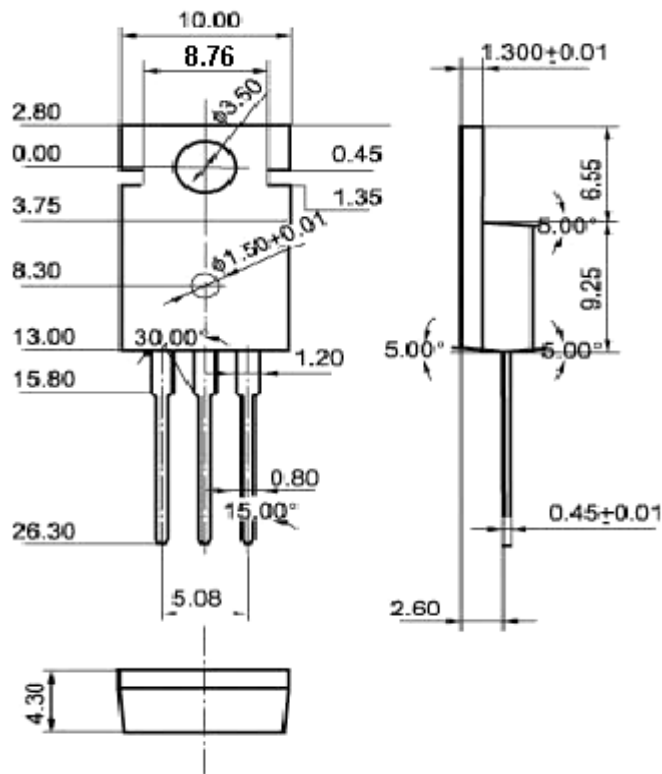

Fig.2 Outline dimensions (unindicated tolerance: ± 0.10 mm)